

FLYINGWINGS LTD

E-Bee KIT & SUPER DEAL



E-Bee

Thanks for buying the E-Bee indoor flyer (its also great outdoors on a calm day). The E-Bee is ideal for novices to expert. The flying characteristics are slow and gentle, but with increased throws becomes quite aerobatic. The front carbon bumper protects the motor and propeller from damage, it will bounce off walls like no other plane.

the items required to finish this kit are:

- 1 x 19-24g 1200-1400kv motor approx 60w *
- 1 x 12A esc or similar *
- 1 x propeller
- 3 x 7-9g servos
- 1 x micro receiver
- 1 x 500-800mah 2S lipo battery
- Transmitter capable of elevon mixing
- Lipo compatible charger
- Glues (UHU Por or hotmelt gun)

* Supplied with Super Deal

Lets get building

Step: 1

Lay the wing face up on a flat smooth surface. Match up the elevons to the back of the wing, the groove should run on the bottom side.
There is two ways of hinging the elevons. Both work extremely well.

Method 1, Hot glue hinge. Butt the elevon and align against the trailing edge (TE)
Put a small blob of hot glue on each end of the hinge line, use an edge of a blade to remove surplus leaving blob smooth. Let it set. Then run a bead of glue down the hinge line and remove surplus glue, wait 15 seconds and move elevon up and down.

Method 2, UHU Por hinge. Run a small bead of glue along the rear top edge of the wing and the same on the leading edge (LE) of the elevon. Allow glue to set for 5 minutes. On a flat surface bring the two edges together, the glue fuses together giving a strong flexible hinge, magic.

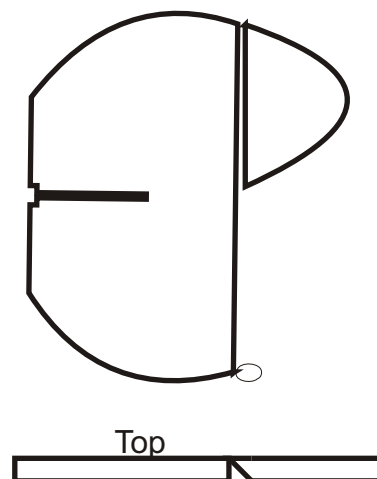

Step: 2

On a flat surface, turn the wing over and place the carbon hoop onto the wing as shown. Align the back section 6mm in from the back of the wing. Check the hoop is central. Check the alignment of the front where the arrows are pointing are even. When satisfied the hoop is aligned, tape in place in a couple of places to hold it in position.

Run UHU Por glue or similar around the outside and inside of the hoop. The glue will form a fillet and some may get under the hoop, this is ok.

Allow to dry for 2 hours

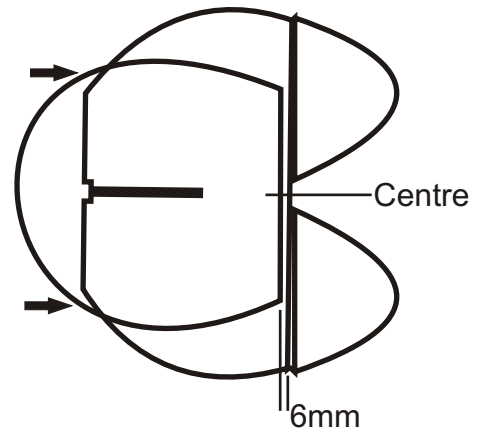

Step: 3

Whilst the wing is setting, attach the undercarriage blocks to the fuselage. Measure back 80mm from the front as shown. the top of the block should approximately parallel to wing slot and 3mm below it. This should give the undercarriage a forward slant. Glue the block on and make a small hole at the top with a piece of piano wire.

When the block has set, push a piece of piano wire through the hole and use it as a guide to glue the other side which should mirror the first block. Remove the wire

Bend the undercarriage legs out of the thicker piano wire, see Fig D on last page

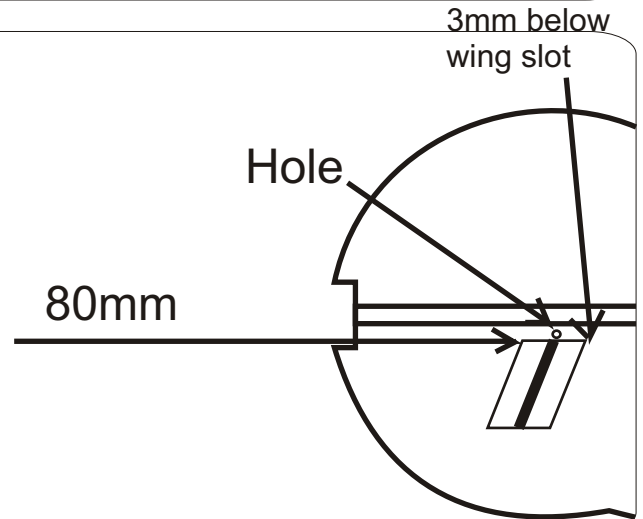

Step: 4

Aircraft assembly: Bring the fuselage to the wing, feed it into the slot on the wing from the front, tail first. Twist it at an angle to clear the carbon bumper.

Align the fuselage to the wing, especially checking the front is aligned centrally. You can spot glue it with CA glue to keep it aligned also putting in a workmate type stand helps here. Check the fuselage is 90 degrees to the wing in along its length. Take your time to get this right.

Glue the rear slot together, allow to dry and set.

Take time to check front alignment

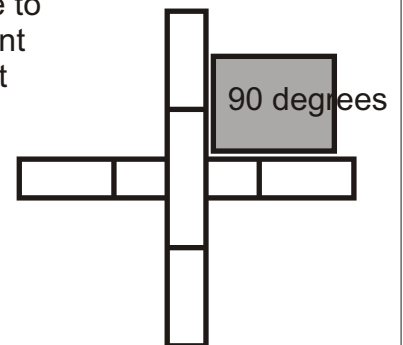

Step: 5

Attach the rudder using one of the techniques outlined in step 1

Fig A

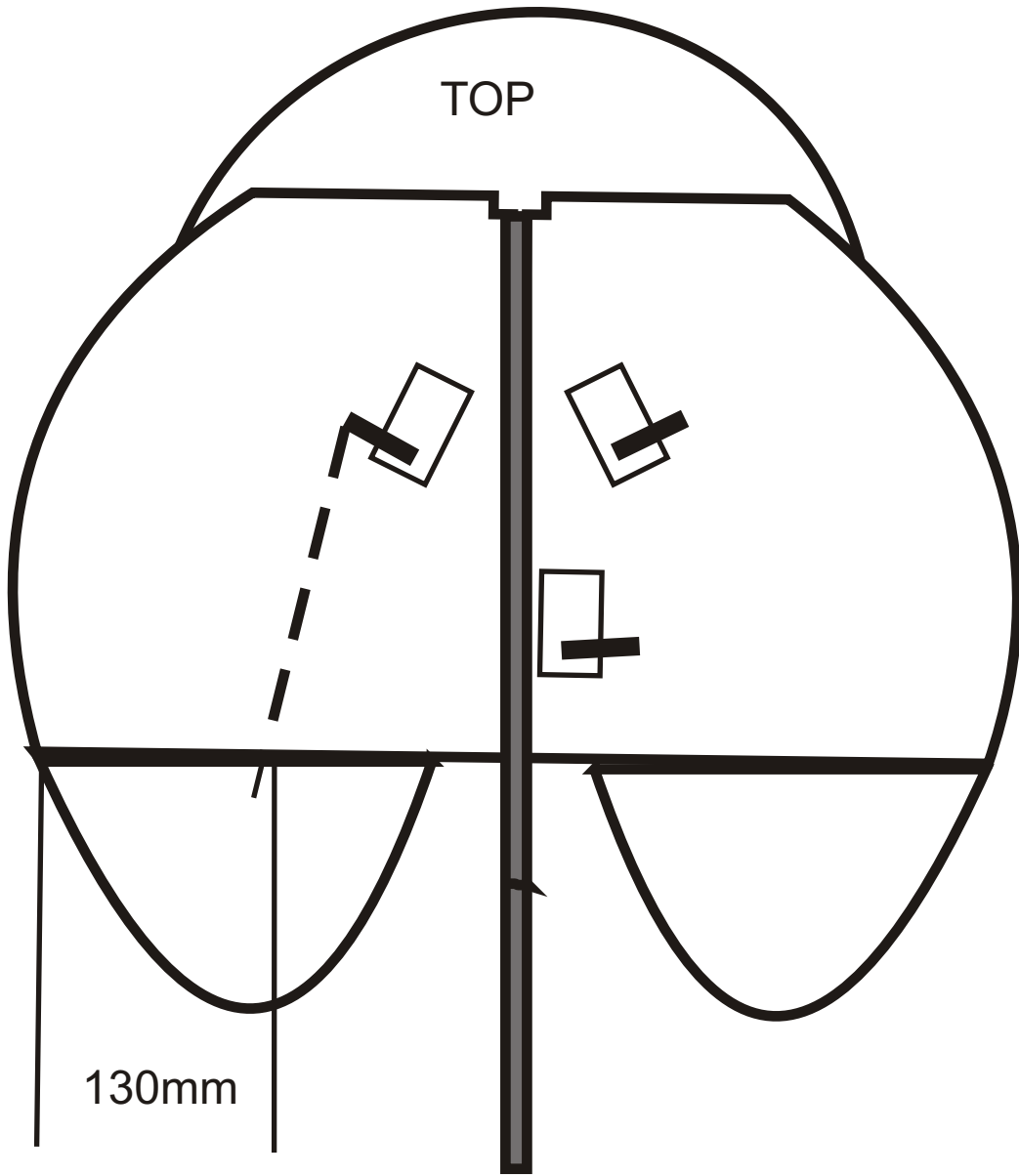

Fig B

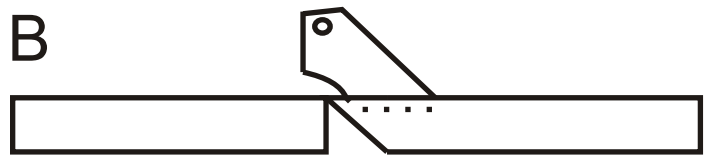
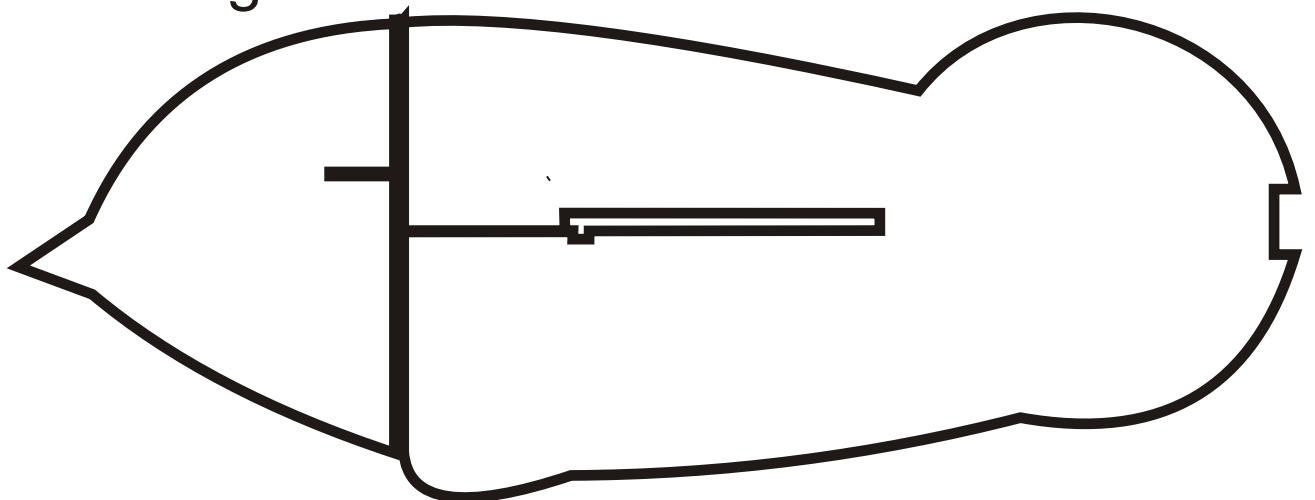

Fig C



Step: 6

FIG A: Run a ruler from the servo horn to the hinge line 130mm from the outer edge, cut a slot for the horn and glue the horn in with CA glue as shown in FIG B with the horn hole in line with the hinge line. Do the other side in the same manner.

FIG C: Cut a slot in the rudder with the horn parallel to the wing at the height of the servo horn.

Use CA glue to secure the servos.

Step: 7

Push rod assembly:

Glue the plastic clevises onto the end of each carbon push rod, clip these onto the servo horns. Attach the piano wire with Z bends onto the ply horns attached to the model.

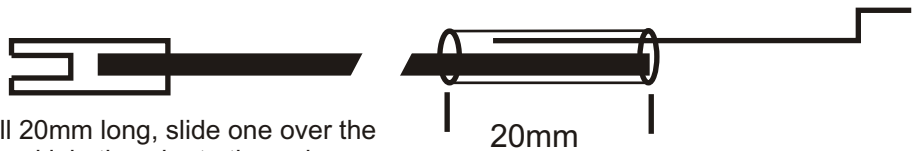

Cut 3 pieces of heatshrink tube all 20mm long, slide one over the carbon rod at the non clevis end and join the wire to the rod, leave it unshrunk at this point

Step: 8

Radio setup

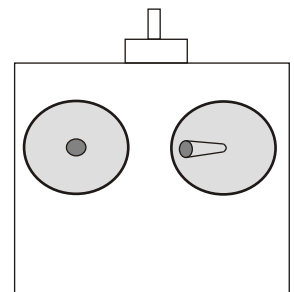
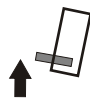

Left Aileron: right servo travels back, left travels forward & vice versa

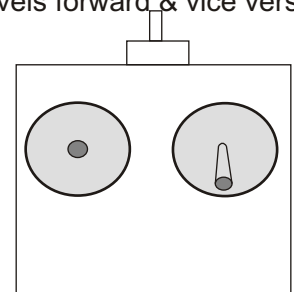
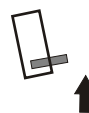
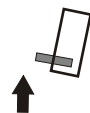

Up Elevator: right servo travels back, left travels back & vice versa

Elevon mixing setup:

If you have a computer radio, set the wing type as elevon or delta, refer to your manual. The 2 servos will plug into the channels for elevator and aileron ie Futaba would be CH1 & CH2.

Set the rudder control so that left moves the rudder left and vice versa.

Step: 9

Motor / Esc setup

Refer's to Super Deal only

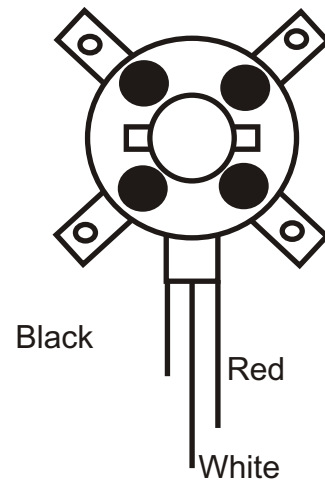
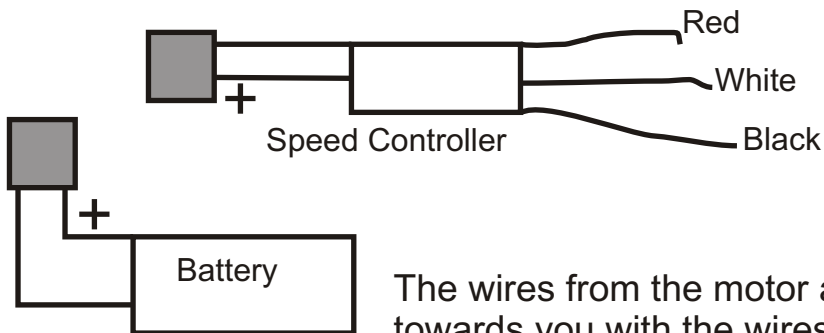

The wires from the motor are black, Face the motor towards you with the wires facing downwards. Connect the left, centre and right wire as shown . If the rotation is incorrect ie clockwise, swap the two outer wires around. Use the heat shrink to isolate each connection.

DO NOT ATTACH THE PROPELLER UNTIL MOTOR TESTING HAS BEEN DONE

Step: 10

Pushrod Adjustment and setting

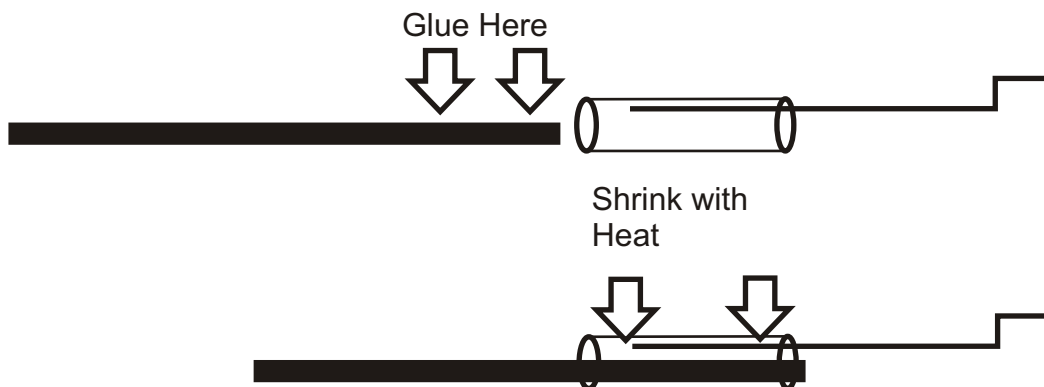

When all your servos have been centralised, drop some CA glue onto the last 20mm of the carbon rod, slide the heatshrink over the rod and wire, set the elevons & rudder to neutral and shrink the tube with a heat gun or hair dryer, be sure not to melt the foam !

Step: 9

Final Assembly and setup



Attach the prop, Push the o-ring behind the screw in the adaptor. Put the Propeller on and wrap the o-ring around and behind the other screw. You may need to lever it with a small screwdriver

Align the motor centrally on the ply plate attached to the EPP block and glue into the front of the fuselage, use plenty of glue.

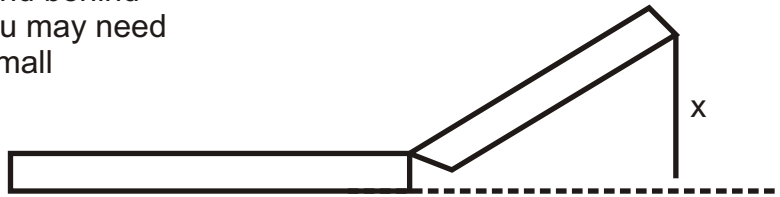
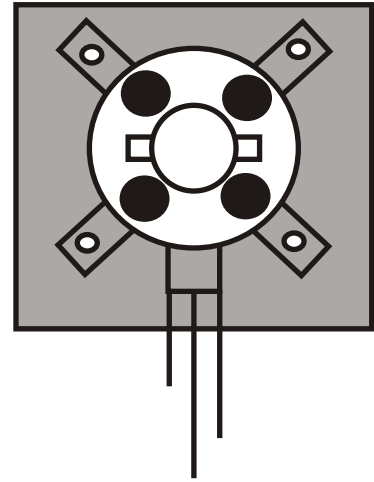

Set Elevon control throws(x) +/- 60mm for beginner, +/- 90mm for expert. Set rudder to +/-75mm

Step: 9

Receiver / ESC / Battery location and balancing

Wrap tape around the receiver and ESC, then glue to fuselage. The battery can be held with velcro

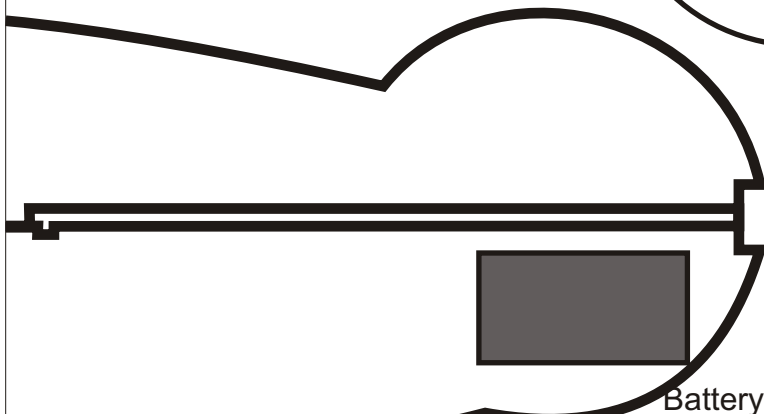
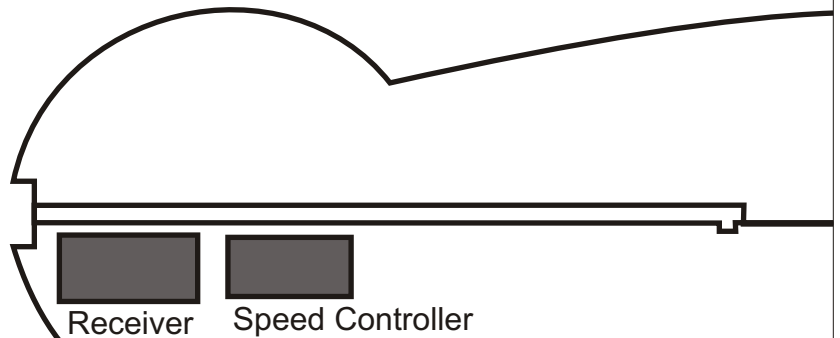

The centre of gravity is 110mm back from the leading edge

Fig D

Undercarriage Template

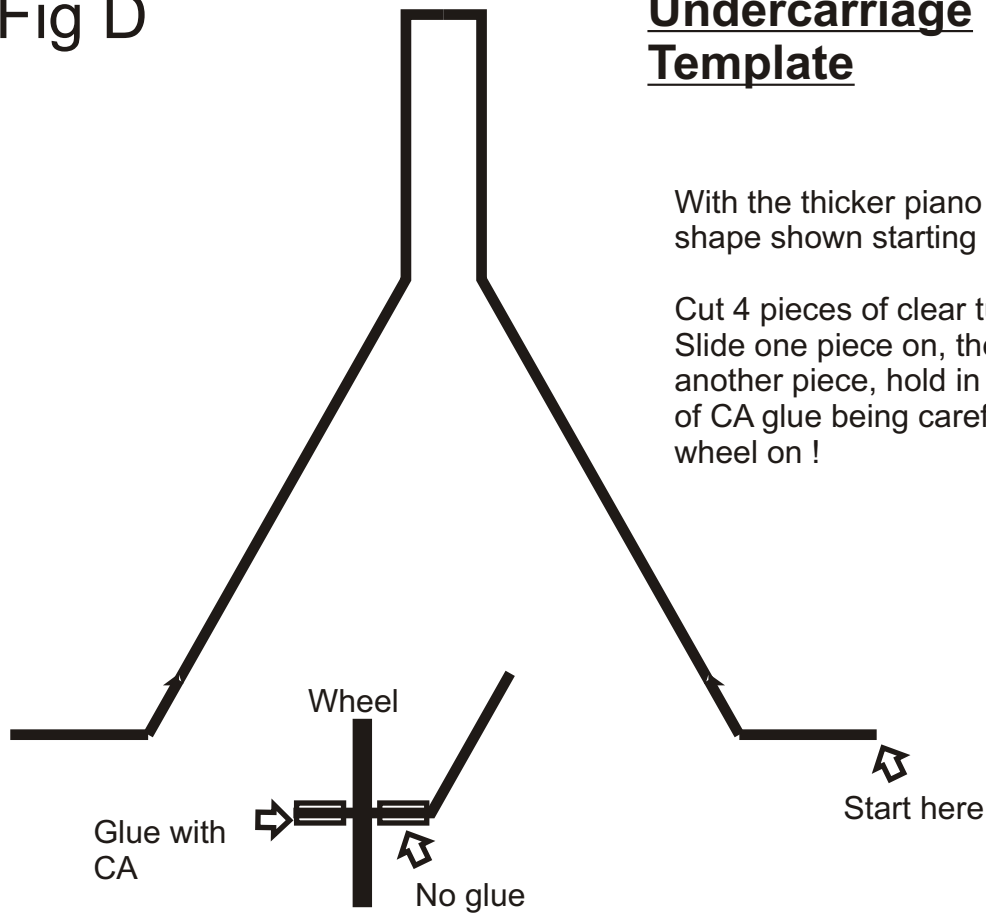

With the thicker piano wire, bend it to the shape shown starting at one end.

Cut 4 pieces of clear tube each 5mm long. Slide one piece on, then the wheel and another piece, hold in place with small blob of CA glue being careful not to glue the wheel on !

Additional photos

