

FLYINGWINGS LTD

HORNET KIT & SUPER DEAL



Thanks for buying the Hornet Park & indoor flyer . The Hornet is ideal for novices to expert. The flying characteristics are slow, gentle and very forgiving, but with increased throws becomes quite aerobatic.

the items required to finish this kit are:

1 x 19-24g 1200-1400kv motor approx 60w *

1 x 12A esc or similar *

1 x propeller

3 x 4.3-6g servos

1 x micro receiver

1 x 540 - 1000mah 2S lipo battery

* Supplied with Super Deal

Transmitter - 4 channel

Lipo compatible charger

Glues (UHU Por or hotmelt gun) & CA (super) Glue with activator

Lets get building

Step: 1

Adding the carbon flat spars to the wing; Put the wing on flat surface. Smear a layer of UHU por along the front edge & back of the wing. Mark the centre of each of the two longer spars supplied. Smear glue on one side of the two spars. Allow to dry for 10 mins, then carefully bond the spars centrally to the front and back, whilst making sure the wing remains flat and true. Repeat using the short carbon spar for the elevator, leave a small gap at the top, as shown.

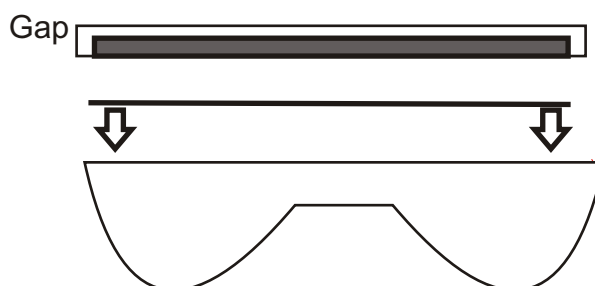
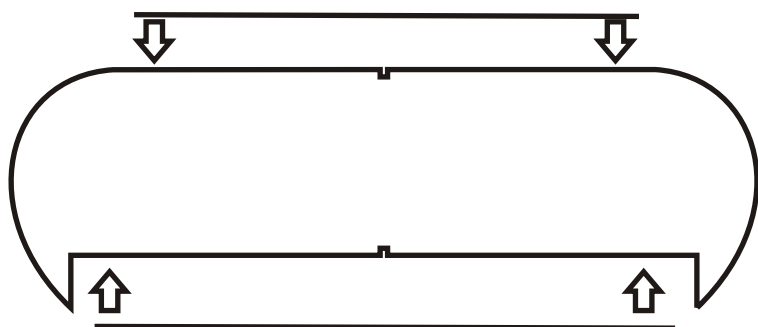

Step: 2

Lay the wing face up on a flat smooth surface. Match up the ailerons to the back of the wing, the groove should run on the bottom side. Hinge the tailplane to the elevator in the same manner.

There is two ways of hinging the ailerons. Both work extremely well.

Method 1, Hot glue hinge. Butt the aileron and align against the trailing edge (TE) Put a small blob of hot glue on each end of the hinge line, use an edge of a blade to remove surplus leaving blob smooth. Let it set. Then run a bead of glue down the hinge line and remove surplus glue, wait 15 seconds and move aileron up and down.

Method 2, UHU Por hinge. Run a small bead of glue along the rear top edge of the wing and the same on the leading edge (LE) of the aileron. Allow glue to set for 5 minutes. On a flat surface bring the two edges together, the glue fuses together giving a strong flexible hinge, magic.

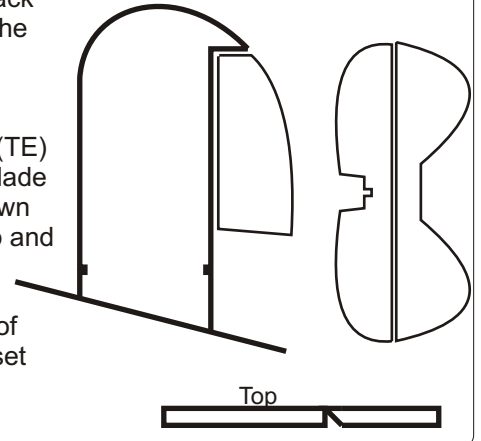

Step: 3

Whilst the wing is setting, attach the undercarriage blocks to the fuselage. Measure back 120mm from the front as shown. the top of the block should approximately parallel to wing slot and 3mm below it. This should give the undercarriage a forward slant. Glue the block on and make a small hole at the top with a piece of piano wire.

When the block has set, push a piece of piano wire through the hole and use it as a guide to glue the other side which should mirror the first block. Remove the wire

Bend the undercarriage legs out of the thicker piano wire, see Fig D on last page

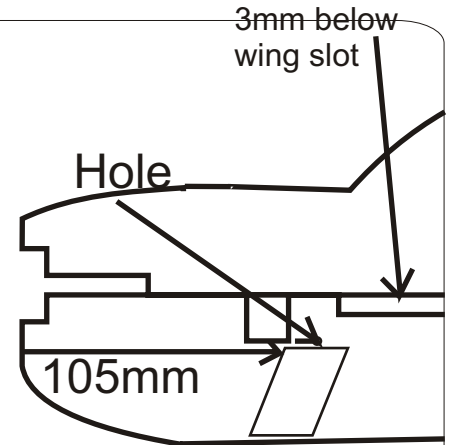

Step: 4

Aircraft assembly: Refer to fig A & C .Assemble the wing dry (no glue) at this stage to familiarise yourself with construction. Insert the wing into the fuselage, you can open the slot, EPP is quite flexible at this stage. Slide the deck on from the front. Insert the tailplane from the rear, the deck should lock into the tailplane. At all times check that all is square.

You can use either UHU por glue of CA glue with activator to glue the model, again checking for squareness at all times. Some modelling or clothes making pins will help here.

Take time to check front alignment

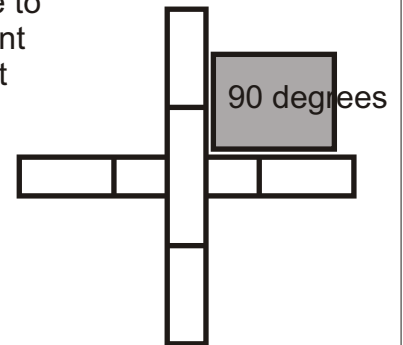

Attach the rudder using one of the techniques outlined in step 1

Step: 5

Glue in the balsa triangular stiffeners, either side of the fuselage behind the wing, all the way to the tail

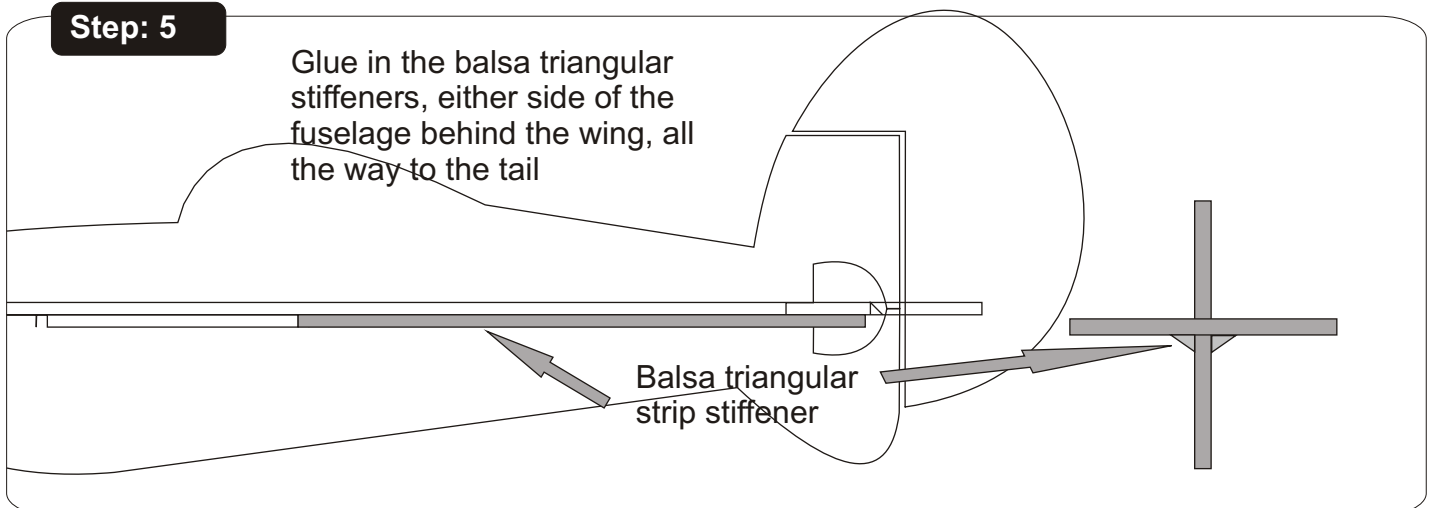

Motor mount

Fig A

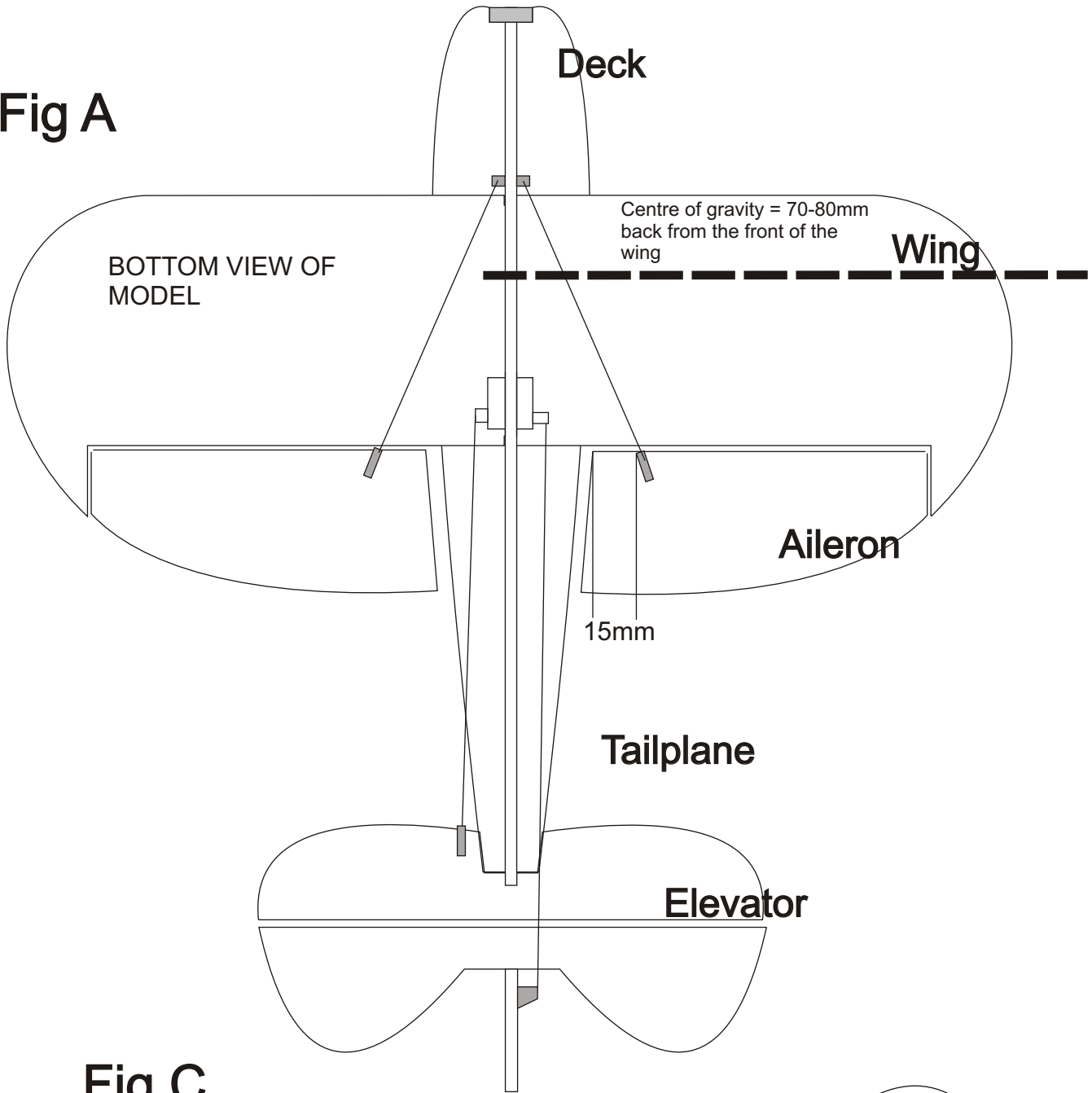

Fig C

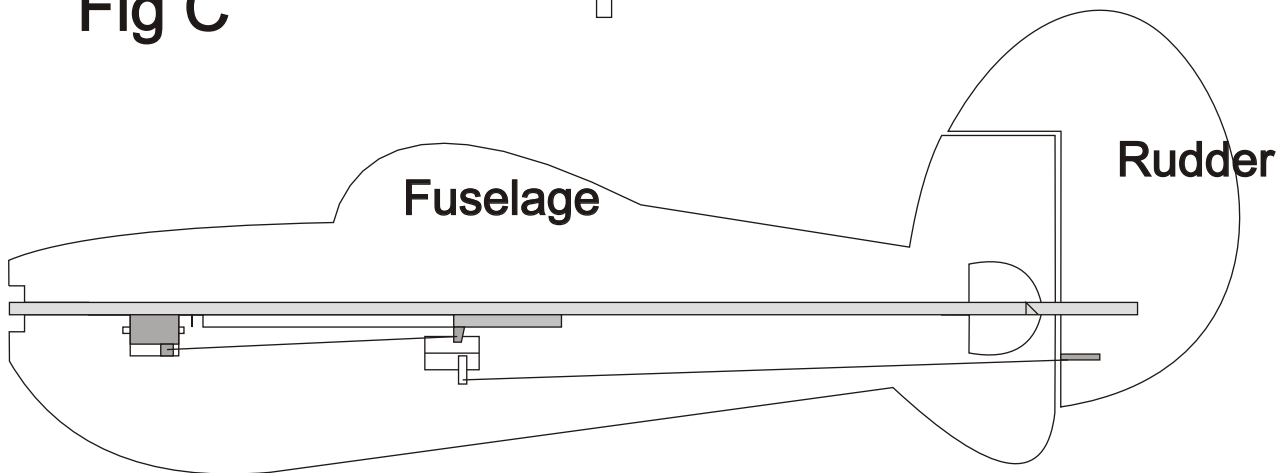
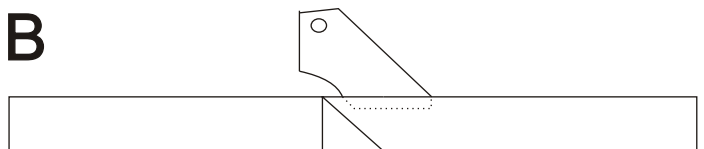

Fig B



Step: 6

FIG A: Run a ruler from the servo horn to the hinge line 15mm from the inner edge, cut a slot for the horn and glue the horn in with CA glue as shown in FIG B with the horn hole in line with the hinge line. Do the other side in the same manner.

FIG C: Cut a slot in the rudder with the horn parallel to the wing at the height of the servo horn.

Use CA glue to secure the servos.

Step: 7

Push rod assembly:

Glue the plastic clevises onto the end of each carbon push rod, clip these onto the servo horns. Attach the piano wire with Z bends onto the the piano horns attached to the model.

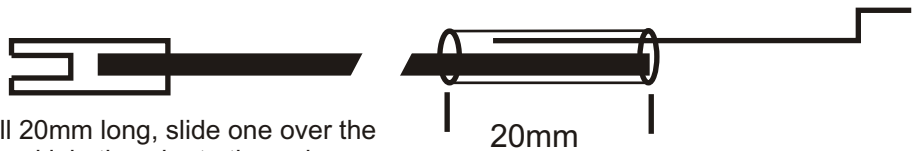

Cut 3 pieces of heatshrink tube all 20mm long, slide one over the carbon rod at the non clevis end and join the wire to the rod, leave it unshrunk at this point

Step: 8

Radio setup

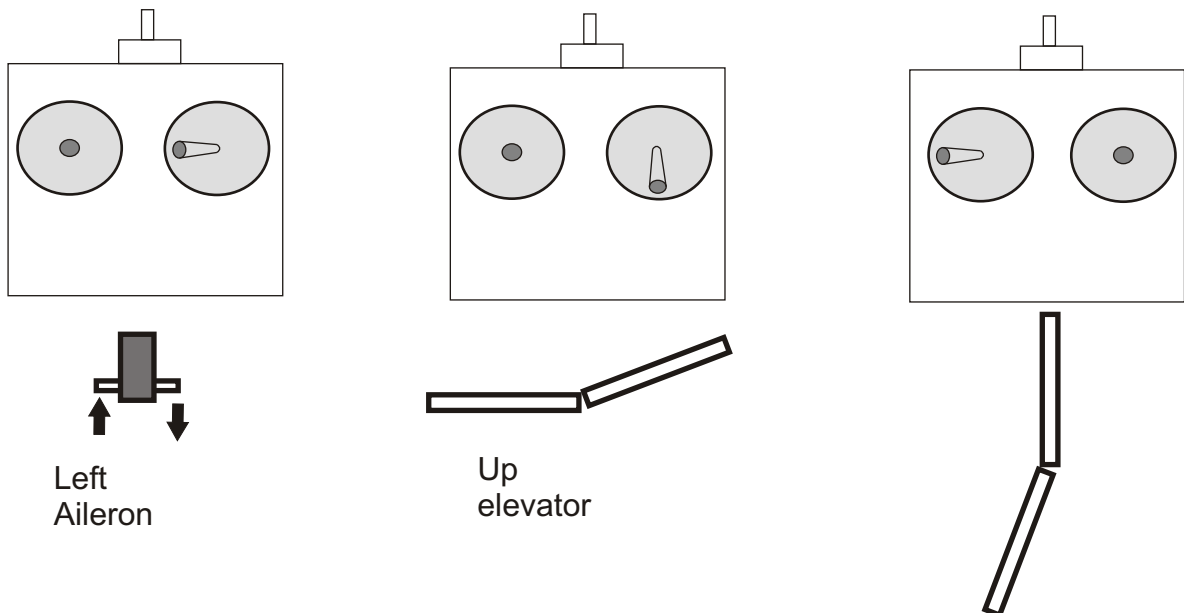

Looking at the model from the top with the nose pointing away.

Aileron: Transmitter, right joystick, left = right aileron moves down, left goes up, vice versa

Elevator, Transmitter right joystick down or back, elevator goes up, vice versa

Rudder, Transmitter left joystick left, rudder moves left vice versa

Step: 9

Motor / Esc setup

Refer's to Super Deal only

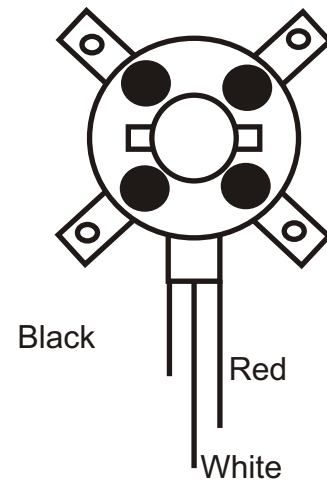
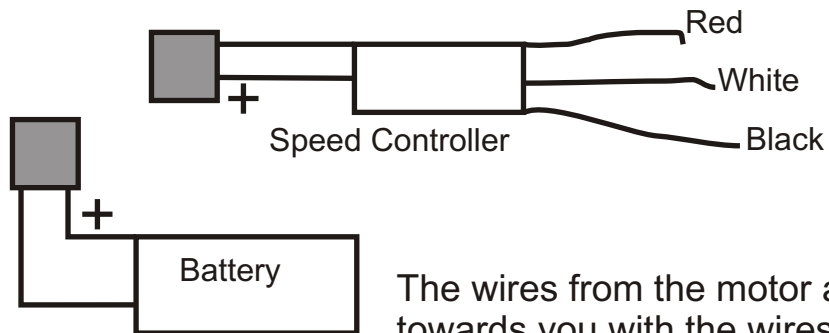

The wires from the motor are black, Face the motor towards you with the wires facing downwards. Connect the left, centre and right wire as shown . If the rotation is incorrect ie clockwise, swap the two outer wires around. Use the heat shrink to isolate each connection.

DO NOT ATTACH THE PROPELLER UNTIL MOTOR TESTING HAS BEEN DONE

Step: 10

Pushrod Adjustment and setting

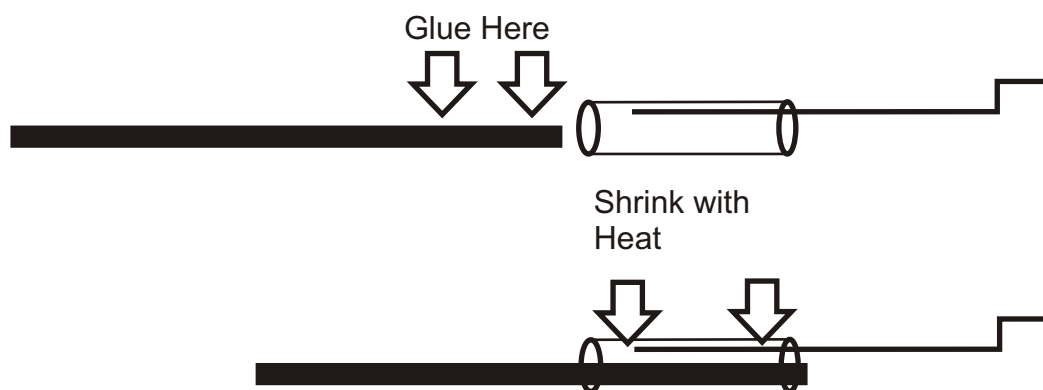

When all your servos have been centralised, drop some CA glue onto the last 20mm of the carbon rod, slide the heatshrink over the rod and wire, set the elevons & rudder to neutral and shrink the tube with a heat gun or hair dryer, be sure not to melt the foam !

Step: 9

Final Assembly and setup



Attach the prop, Push the o-ring behind the screw in the adaptor. Put the Propeller on and wrap the o-ring around and behind the other screw. You may need to lever it with a small screwdriver

Align the motor centrally on the ply plate attached to the EPP block and glue into the front of the fuselage, use plenty of glue.

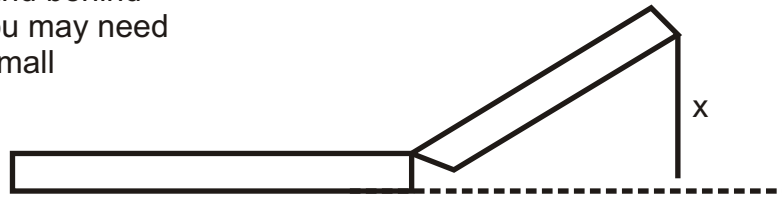
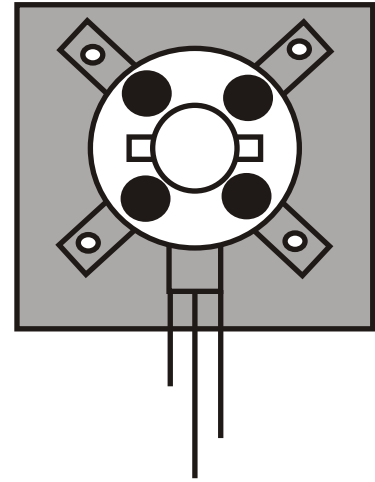

Set Elevon control throws(x) +/- 60mm for beginner, +/- 90mm for expert. Set rudder to +/-75mm

Step: 9

Receiver / ESC / Battery location

Wrap tape around the receiver and ESC, then glue to fuselage. The battery can be held with velcro



The centre of gravity is on the wing carbon spar.



Fig D

Undercarriage Template

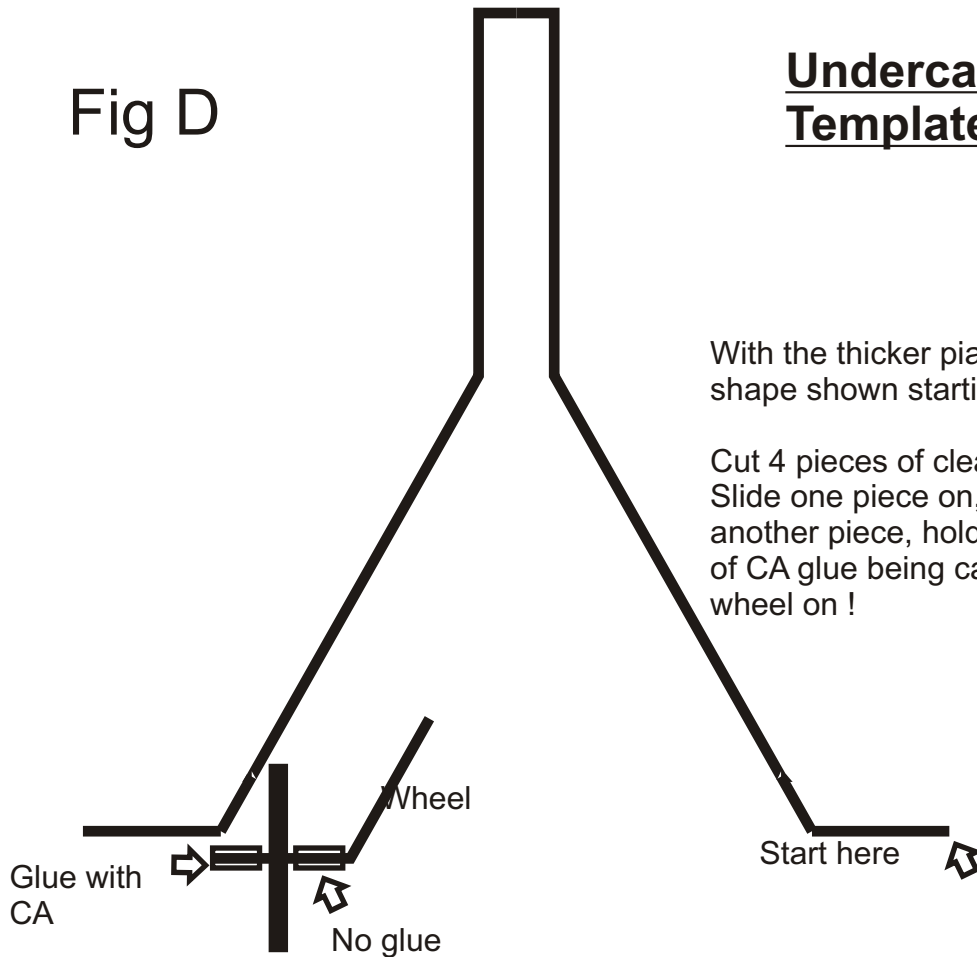

With the thicker piano wire, bend it to the shape shown starting at one end.

Cut 4 pieces of clear tube each 5mm long. Slide one piece on, then the wheel and another piece, hold in place with small blob of CA glue being careful not to glue the wheel on !

Flying the Hornet

If you wish to adjust the flying characteristics of the model, loosen the two top screws holding the motor on.

Put a spacer ie washer of 2mm depth to give some down thrust, you may need some up elevator to compensate.

