

FLYINGWINGS LTD

PRO-CUT 3D series

Covers: Sukhoi, Yak54, Fizz XL



Thanks, for buying a Pro-Cut 3D kit. These kits are designed for outdoor use, but can be used in larger indoor halls with a 2cell lipo. Assembly is straight forward and in a short time you will have a great fun 3D aerobatic model. These kits will perform all the tricks in the book, and you can be confident that the Pro-Cut's will withstand more punishment than any other 3D kit.

the items required to finish this kit are:

1 x 45g 1100-1400kv motor approx 90-120w *

1 x 20-30A esc or similar *

1 x propeller

3 x 7.5g-9g servos

* Supplied with Super Deal

1 x micro receiver 4 channel

1 x 740-1000 3S lipo battery (outdoors) 740mah 2s (indoors)

Transmitter - 4 channel

Lipo compatible charger

Glues (UHU Por or hotmelt gun) & CA (super) Glue with activator

Lets get building

Step: 1

Lay the wing face up, use UHU por to glue the two wing halves together.

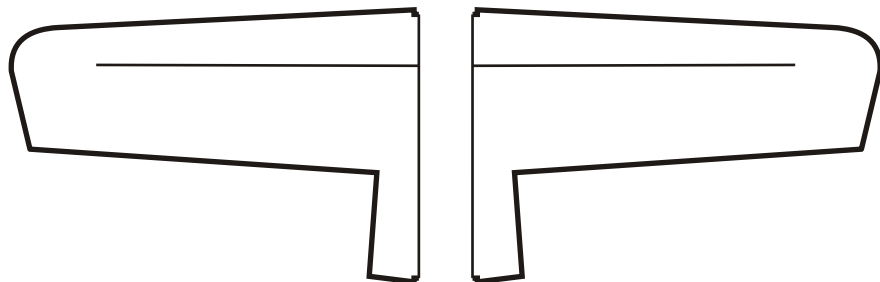

Step: 2

Adding the flat carbon spars: You will find one long CF spar and one short one. Lay the wing on a flat surface and slot in the long spar into the pre-cut wing slot. Use CA glue to secure from the top, then from the bottom of the wing.

Lay the tailplane on a flat surface and glue the short spar to edge of the tailplane as shown, the spar should sit on the bottom giving you a small gap at the top. Hold in position with tape.

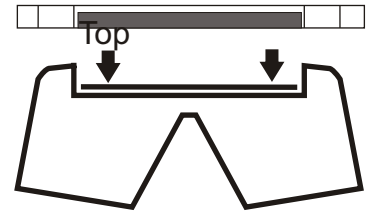
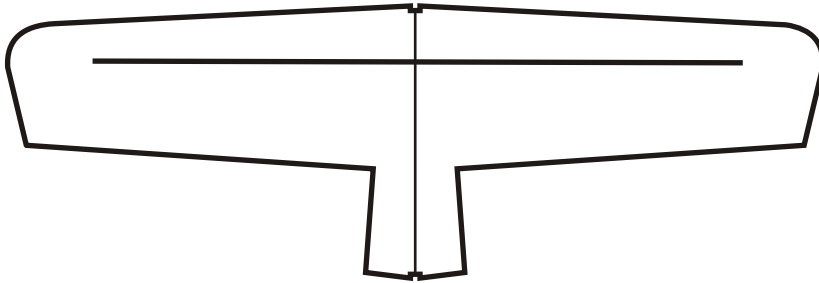

Step: 3

Lay the wing face up on a flat smooth surface. Match up the ailerons to the back of the wing, the groove should run on the bottom side. Hinge the tailplane to the elevator in the same manner.

There is two ways of hinging the ailerons. Both work extremely well.

Method 1, Hot glue hinge. Butt the aileron and align against the trailing edge (TE) Put a small blob of hot glue on each end of the hinge line, use an edge of a blade to remove surplus leaving blob smooth. Let it set. Then run a bead of glue down the hinge line and remove surplus glue, wait 15 seconds and move aileron up and down.

Method 2, UHU Por hinge. Run a small bead of glue along the rear top edge of the wing and the same on the leading edge (LE) of the aileron. Allow glue to set for 5 minutes. On a flat surface bring the two edges together, the glue fuses together giving a strong flexible hinge, magic.

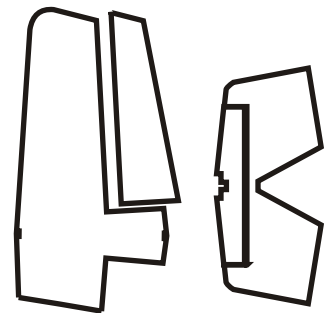

Step: 4

Aircraft assembly: Refer to fig A & C .Assemble the wing dry (no glue) at this stage to familiarise yourself with construction. Insert the wing into the fuselage, you can open the slot, EPP is quite flexible at this stage. Slide the deck on from the front. Insert the tailplane from the rear, the deck should lock into the tailplane. At all times check that all is square.

You can use either UHU por glue of CA glue with activator to glue the model, again checking for squareness at all times. Some modelling or clothes making pins will help here.

Take time to check front alignment

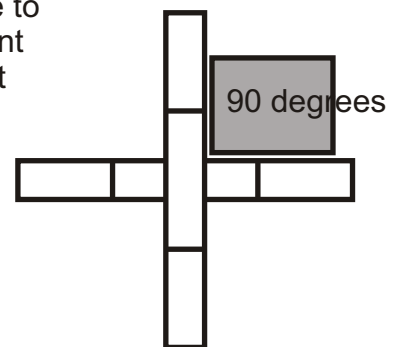

Step: 5

Glue the ply motor mount to the epp backing block.

Slot the assembly into the front of the aircraft, check that its lined up both vertically and horizontally. Glue in place with plenty of glue.

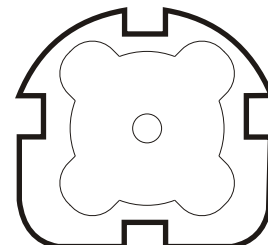

Motor mount

Fig A

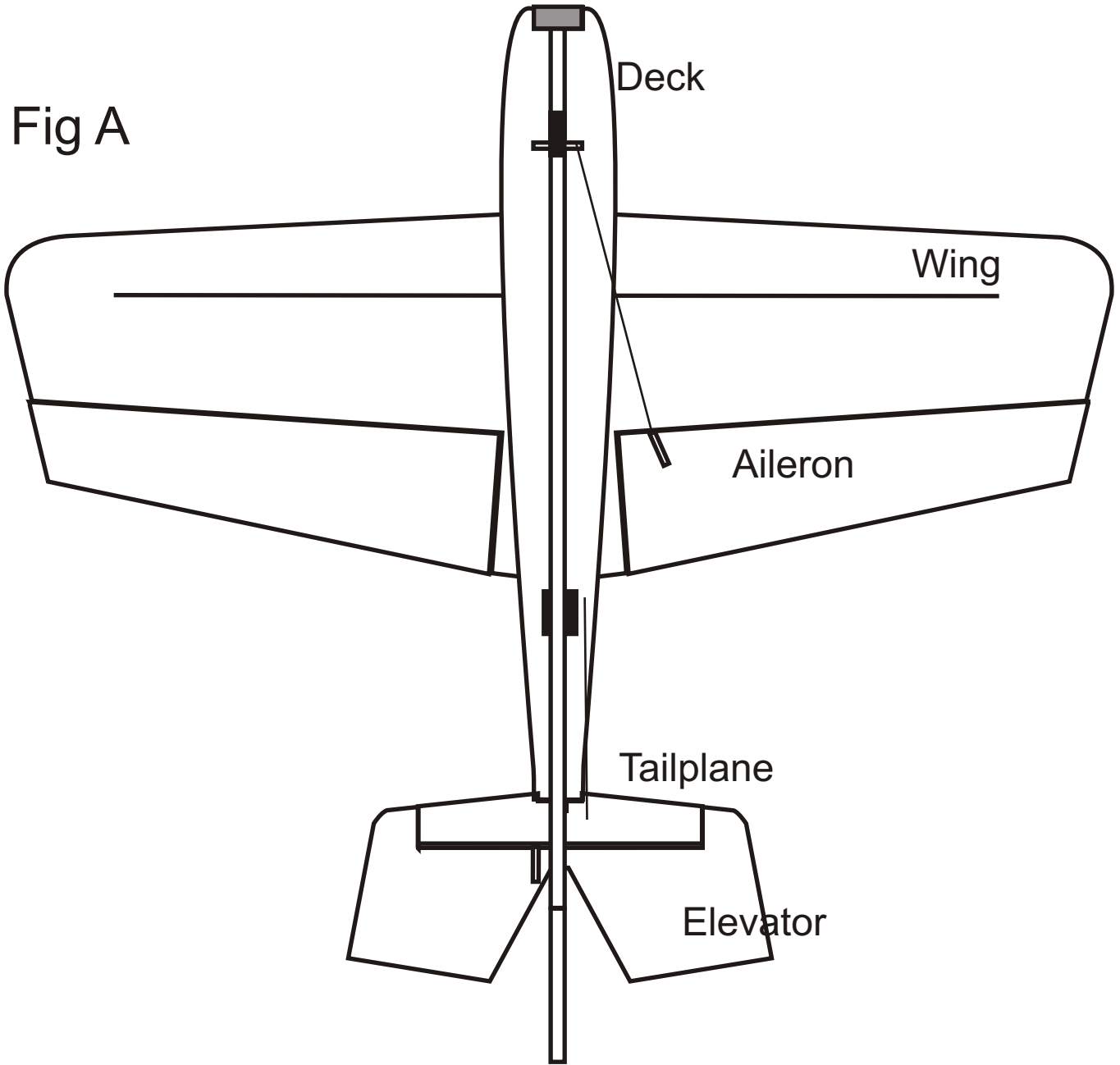

Fig C

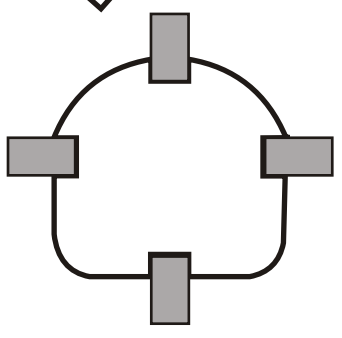
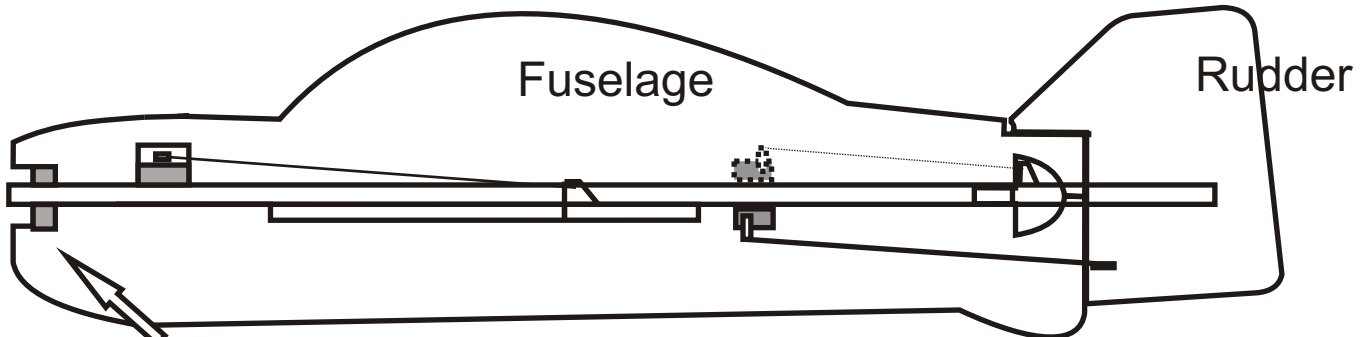
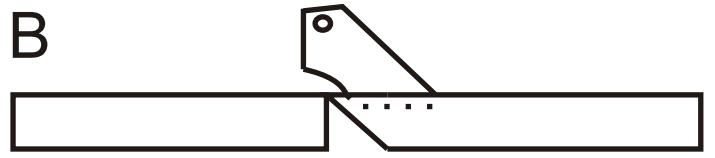

Fig B



Step: 6

FIG A: Run a ruler from the servo horn to the hinge line 130mm from the outer edge, cut a slot for the horn and glue the horn in with CA glue as shown in FIG B with the horn hole in line with the hinge line. Do the other side in the same manner.

FIG C: Cut a slot in the rudder with the horn parallel to the wing at the height of the servo horn.

Use CA glue to secure the servos.

Step: 7

Push rod assembly:

Glue the plastic clevises onto the end of each carbon push rod, clip these onto the servo horns. Attach the piano wire with Z bends onto the the ply horns attached to the model.

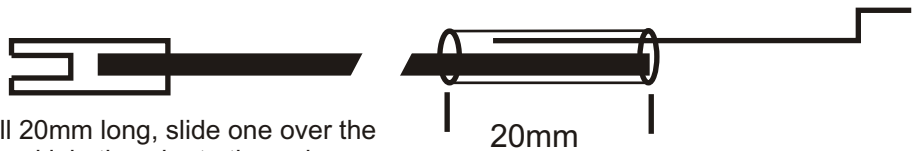

Cut 3 pieces of heatshrink tube all 20mm long, slide one over the carbon rod at the non clevis end and join the wire to the rod, leave it unshrunk at this point

Step: 8

Radio setup

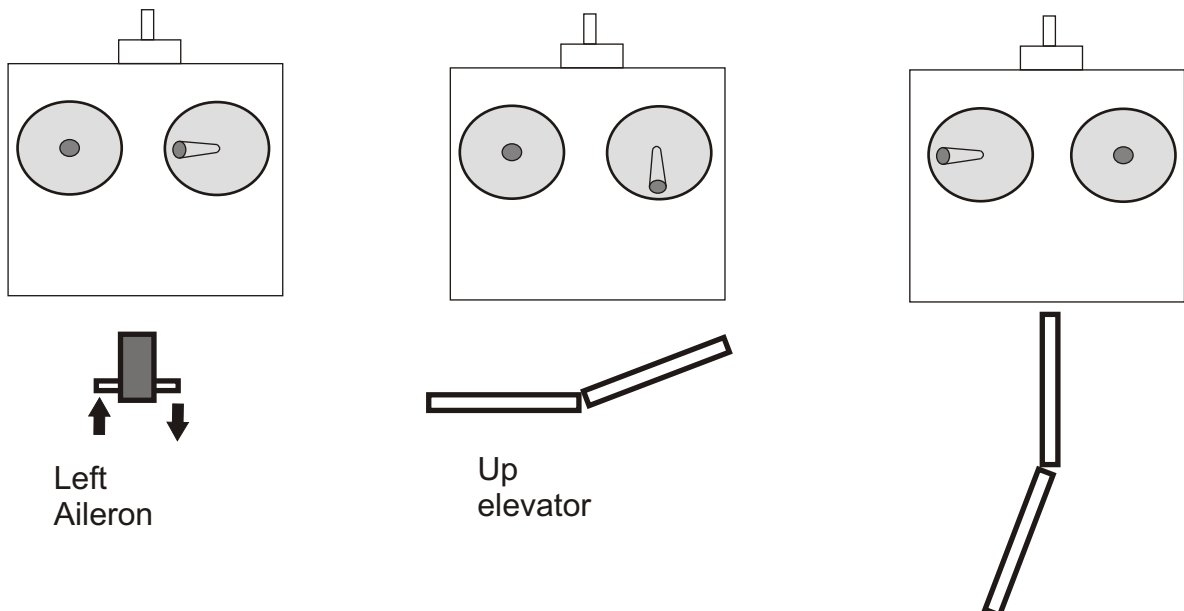

Looking at the model from the top with the nose pointing away.

Aileron: Transmitter, right joystick, left = right aileron moves down, left goes up, vice versa

Elevator, Transmitter right joystick down or back, elevator goes up, vice versa

Rudder, Transmitter left joystick left, rudder moves left vice versa

Step: 9

Motor / Esc setup

Refer's to Super Deal only

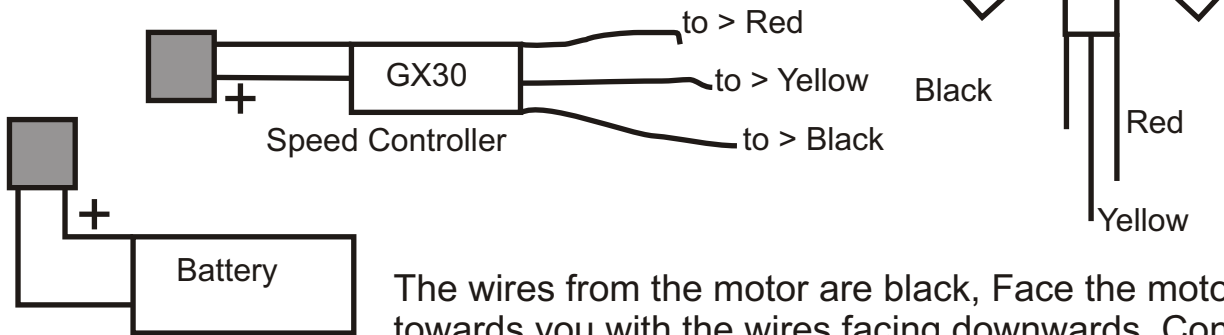

The wires from the motor are black, Face the motor towards you with the wires facing downwards. Connect the left, centre and right wire as shown . If the rotation is incorrect ie clockwise, swap the two outer wires around. Use the heat shrink to isolate each connection.

DO NOT ATTACH THE PROPELLER UNTIL MOTOR TESTING HAS BEEN DONE

Step: 10

Pushrod Adjustment and setting

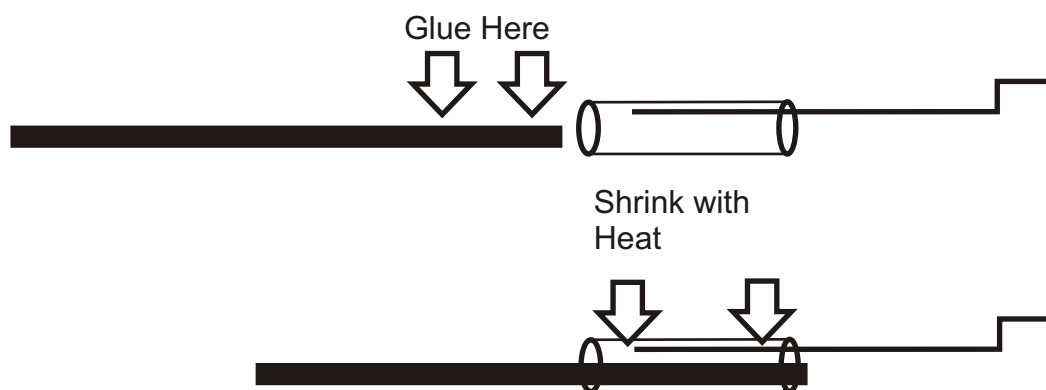

When all your servos have been centralised, drop some CA glue onto the last 20mm of the carbon rod, slide the heatshrink over the rod and wire, set the elevons & rudder to neutral and shrink the tube with a heat gun or hair dryer, be sure not to melt the foam !

Step: 9

Final Assembly and setup



Attach the prop, Push the o-ring behind the screw in the adaptor. Put the Propeller on and wrap the o-ring around and behind the other screw. You may need to lever it with a small screwdriver

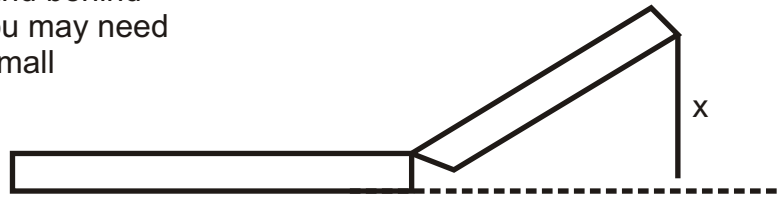

Control Throws (x)	Beginner	Expert
Aileron +/-	30mm	50mm
Elevator +/-	30mm	50mm
Rudder +/-	40mm	60mm

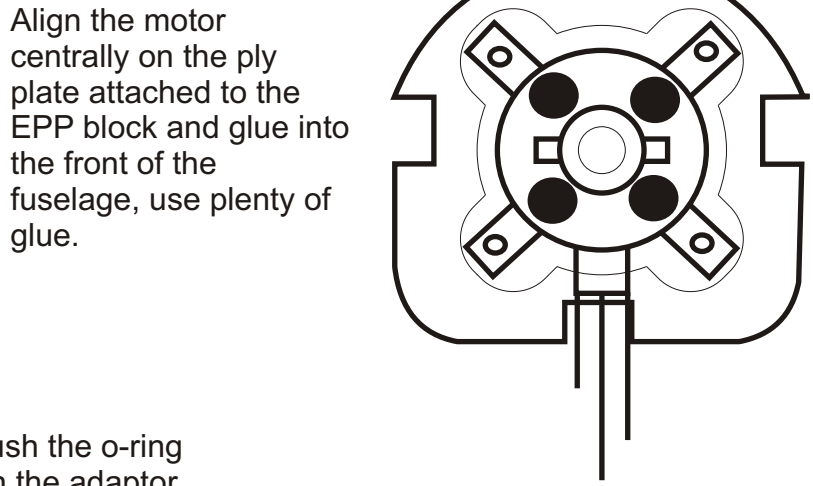

Align the motor centrally on the ply plate attached to the EPP block and glue into the front of the fuselage, use plenty of glue.

Step: 9

Receiver / ESC / Battery location and balancing

Wrap tape around the receiver and ESC, then glue to fuselage. The battery can be held with velcro

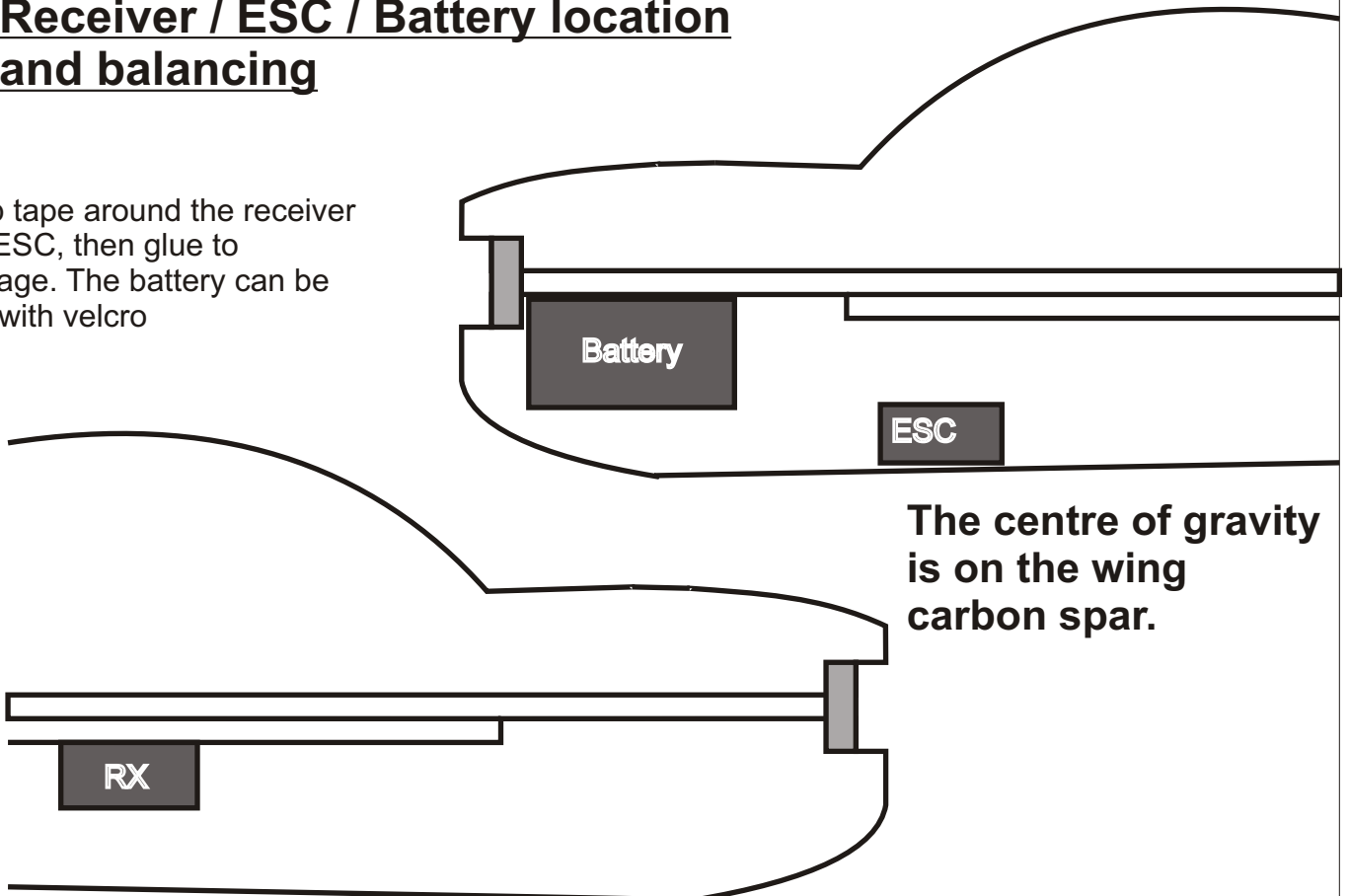

The centre of gravity is on the wing carbon spar.

Additional photos

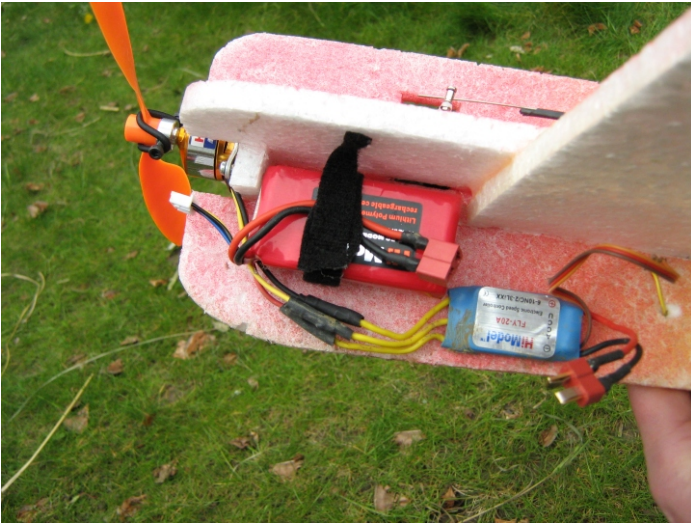

Help Line 01908 615163
sales@flyingwings.co.uk

GET INSURED
AT WWW.BMFA.ORG